

Powerware series

225–1100 kVA

Eaton 9395 UPS



EATON

Powering Business Worldwide

Introduction and overview

With an unprecedented level of power performance, reliability and energy savings, the state-of-the-art Eaton® 9395 UPS has raised the bar in three-phase power protection technology. As IT managers, facility managers and CIOs feel increasing pressure to achieve zero downtime, and to scale the data center to meet ever-changing requirements, the search for the most reliable and efficient power protection system has become even more critical. But that search is now over. For more than 40 years, Eaton has been dedicated to delivering the most technologically advanced products for our customers' mission-critical applications—a commitment exemplified by the new 9395. More than an innovative, cutting-edge UPS, it's a quantum leap in three-phase technology.

The 9395 delivers a wide scope of superior customer-driven benefits unmatched by competitive UPS solutions, including:

Leading sustainability

- Highest efficiency ratings lower utility costs
- Lowest total cost of ownership and lifecycle carbon footprint
- Smallest footprint and weight
- Lowest transportation and installation costs

Stronger power performance

- Lowest input THD enhances compatibility with upstream power systems
- Lowest output THD
- Optimum generator sizing
- PFC power supply compatible

Highest reliability and availability

- Powerware Hot Sync® wireless paralleling
- Superior battery management
- Inherent redundancy
- Scalable architecture adapts to increasing power requirements

Robust manageability

- Superior control and connectivity

Key applications

- Large data centers
- Server farms
- Telecommunication installations
- Internet service providers
- Transportation systems
- Security operations
- Broadcasting and entertainment
- Process control equipment
- Financial systems
- Credit card operations
- Healthcare
- Industrial systems
- Multiple medical imaging units

The reliable solution

When it comes to reliability, the 9395 leaves competitive UPSs in the dust. Providing high availability for your critical systems at all times, the 9395 was designed with numerous technological advancements that create an unprecedented level of reliability while emphasizing serviceability—lowering MTTR and enhancing availability.

Double-conversion design offers the highest protection possible

Unlike some other commercially available UPS technologies, the double-conversion design completely isolates output power from all input power anomalies and delivers 100-percent conditioned, perfect sine-wave output—regulating both voltage and frequency. Even when presented with the most severe power disturbances, power output remains stable. Output voltage

THD is held within two percent of nominal specification for linear loads, and within five percent for nonlinear loads—making the 9395 ideal for supporting equipment that is sensitive to a distorted voltage input. Additionally, the 9395 excels at supporting leading power factor loads, which are becoming more prevalent in new or updated data centers. The 9395 handles leading loads, down to 0.9 power factor without derating.

Inherent redundancy option

Surveys focused on efficiency in data centers reveal that UPSs are often under-loaded—frequently at less than 50 percent. To capitalize on this trend and create even greater reliability, you have the option to configure the 9395 with inherent redundancy. Traditional UPS manufacturers cannot deliver this additional availability without adding a more costly second UPS module.

Inherent redundancy option:
When at or below 50% capacity, the 9395's uninterruptible power modules (UPMs) automatically act as N+1 redundant systems



UPM #1

UPM #2

Eaton 9395 550 kVA

Powerware Hot Sync technology: The culmination of power reliability and systems availability

In systems with multiple uninterruptible power modules (UPMs), the 9395 leverages the synchronization, load sharing and selective trip capabilities of Eaton's patented Powerware Hot Sync® technology. These capabilities are integral to the ultimate systems availability that is the primary requirement for any parallel UPS configuration.

How does Eaton do it better?

Powerware Hot Sync utilizes a peer to peer control architecture, as opposed to the ubiquitous master/slave controls found in competitive systems. This unique architecture eliminates the need for a single UPM to depend on any outside source for its control. The multiple UPMs simply monitor their own internal metering, and use simple mathematical computations to remain synchronized, share the load equally, and detect and isolate malfunctions. This wireless architecture, eliminates huge bundles of control wiring, hundreds of electrical connections, and removes the need for a failure-prone central control.

Ultimate reliability in the implementation of parallel AC power systems has been proven over the past four decades to be a function of the following two key attributes: System autonomy and simple instrumentation.

The Hot Sync system functions automatically without any dependence on centralized, external control.

Furthermore, because Powerware Hot Sync systems do not require extra circuitry or added complex wiring in order to function in parallel, these designs significantly enhance reliability over other parallel systems that utilize elaborate sync control loop wiring, load share error loop wiring, selective trip detection loops, mechanical relays, multiple specialized PC boards, extra EMI isolation and specialized firmware. The failure of any of these complex controls results in an unstable system. Hot Sync eliminates this complexity, enhancing reliability.

Key design features of Hot Sync systems

- No system-level single point of failure
- Paralleled UPMs operate completely independently. One module cannot affect or interfere with the others – no domino effect scenario
- No added circuitry is required for parallel operation. Any standard UPS can be used in a parallel system without modification
- This patented and proven technology, has been successfully deployed in thousands of systems around the world.

Sync Control technology

Sync Control ensures that the output of two (or more) separate UPSs (single modules or parallel systems) remain in phase with one another so static transfer switches connected between the separate distribution paths may change state seamlessly when necessary.

Static Auto Tie

The Static Auto Tie (SAT) system enhances reliability even further so full load transfers can be made autonomously. The SAT system adds a single wrap-around static switch to the tie breaker in the Hot-Tie system, then adds intelligent controls so a power protection system made up of two or more separate UPS systems can **automatically transfer entire** loads in the event of failure of one side of an A/B distribution system. This eliminates the need for numerous downstream static switches and costly wiring.

In the SAT configuration displayed in the diagram below, there is a static auto tie circuit between the outputs of the two UPS modules that automatically transfers the loads from one to the other as necessary. This less complex, dual-path architecture streamlines the distribution system to eliminate series switching elements and reduce the potential downtime of single power cord loads by up to 50 percent. As a result, the SAT architecture offers a number of benefits, including:

- Reduced capital expenses and installation costs
- Eliminates need for traditional downstream static transfer switches
- Increased system reliability and efficiency
- Decreased maintenance requirements
- Reduced raised floor space requirements

Fully Deployed Static Auto Tie Configuration

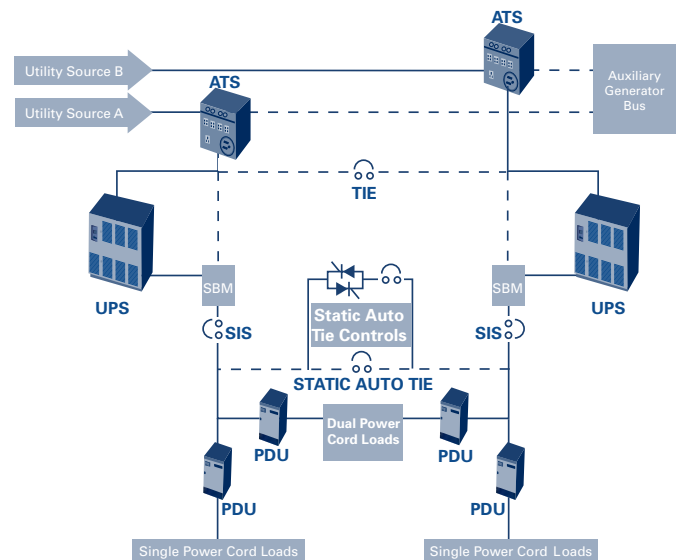

Batteries: The heart of every UPS

When a utility power outage causes a UPS to switch to battery power, it is imperative that those batteries are healthy, charged and up to the task. Improper battery management is the number one cause of downtime. Many UPS batteries on the market today are constantly trickle-charged—a process that degrades the battery's internal chemical composition over time, reducing potential battery service life by as much as 50 percent. To address this, the 9395 uses a sensing circuit and an innovative three-stage charging technique to significantly extend battery service life and optimize recharge time. In addition, temperature-compensated charging monitors temperature changes, and adjusts the rate of charge to prolong battery life.

Monitor batteries for optimum readiness

Advances in firmware and digital technology enable the 9395 to offer sophisticated battery monitoring and management features that you might expect to find only on expensive add-on systems, including:

- Battery runtime remaining monitor uses system loading and trended battery discharge data plus internal sensing points for voltage and current data to calculate runtime remaining
- Battery circuit test performs a periodic full-load test of the battery string to ensure that there are no open circuits or weak cells that would jeopardize battery performance and system availability

In addition to these integrated monitoring features, we offer one year of secure, remote monitoring to provide 7x24 real-time monitoring of more than 100 UPS and battery alarms with eNotify. This real-time information is critical in helping you make management decisions, from scheduling preventive maintenance to determining the best way to reduce loads during an outage.

By ensuring optimal battery health and availability, battery monitoring features raise the reliability of the Eaton 9395 beyond any other UPS in its class.

1. Refer to the Eaton Electrical Inc. Limited Factory Warranty for three-phase UPS products for specifications, limitations, and terms. Service and support specifications may vary by country.

Service and support enhance performance

Eaton recognizes that superior power reliability requires flawless execution from its services team. Every 9395 includes an on-site startup from a factory-trained field technician to insure proper installation, operation, and customer training. In addition, we include a full year of on-site 7x24 parts and labor warranty and service protection plan coverage at no extra charge. Finally, our experts will remotely diagnose, trend, and proactively spot problems and expedite field technicians with appropriate parts when required during the first year with our advanced eNotify Remote Monitoring Service. Included at no extra charge with every 9395:

- 7x24x365 startup service and customer training
- One-year limited factory warranty¹
- Service protection plan 7x24 coverage, eight-hour response (upgrade to four- or two-hour where available), parts and labor, unlimited on-site emergency response support
- eNotify Remote Monitoring Service: 7x24 critical alarm notification and monthly reports on UPS and battery health
- 7x24 technical support access



In addition to the warranty and first year of on-site coverage, Eaton offers a wide variety of support agreements for continued preventive and emergency response maintenance. PowerTrust Service Plans include:

- UPS and battery scheduled preventive maintenance
- Parts and labor coverage for electronics and/or batteries
- Factory-trained technicians with genuine Eaton parts and diagnostic tools
- eNotify Remote Monitoring Service
- Available coverage: 7x24, eight/four/two-hour response, or 8x5 next business day response
- 7x24 technical support access

eNotify Remote Monitoring Service

All PowerTrust Service Plans include Eaton's eNotify Remote Monitoring Service, enabling Eaton service technicians to remotely monitor your UPS and batteries using one-way e-mails. With technical experts available to respond immediately and resolve many issues remotely, eNotify features 7x24 real-time monitoring of 100+ UPS and battery alarms.

The eNotify service provides you with monthly reports detailing the ongoing health of your 9395 UPS. The Customer Monitoring Report delivers information on your unit's voltages, loads, and external factors such as temperature and humidity. Additionally, the report provides information about the attached batteries and system availability. All of these factors contribute to the Relative Health Index (RHI) score that allows you to compare your unit's health to Eaton's optimum operating levels.

Proactive monitoring is also included. Upon receipt of both status and event e-mails, anomalies are checked for incoming parametric or event data logs. If an anomaly is detected, Eaton analysts further study the data for possible impending failures and take appropriate action. The following critical alarms are provided by eNotify:

- UPS output power will turn off after the configured delay period
- Low battery alarm present
- UPS hardware fault detected
- UPS battery completely discharged
- UPS inverter fault detected
- UPS internally bypassed
- UPS output has been turned off
- UPS shutdown imminent alarm condition exists
- The failure of one or more fuses has been detected
- A relay, contactor, or breaker has failed

The eNotify Remote Monitoring Service provides confidence that Eaton is continually watching your 9395 and will combine its technical resources and field technicians as needed to quickly respond to critical alarms.

The innovative design of the Eaton 9395 delivers the industry's best performance combination of high efficiency, low input current distortion and high power factor.

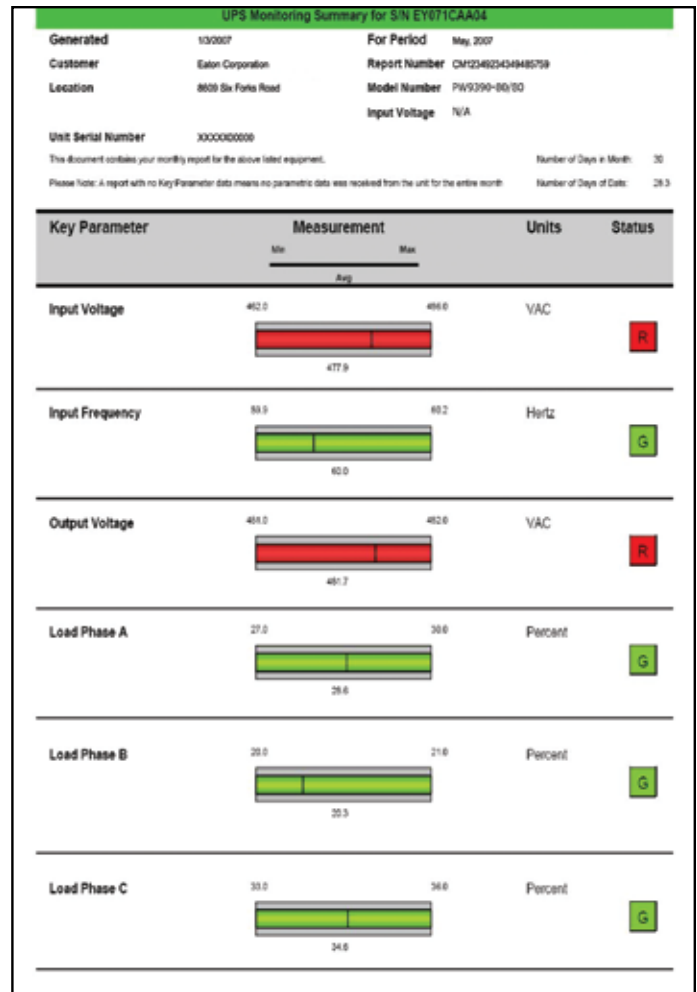

Sent via email to as many as six site contacts, the eNotify monthly Customer Monitoring Report provides a summary of the top 10 performance and environmental parameters, battery events, availability percentage, and comparative status against recommended specification.

Unmatched green power performance

The innovative design of the 9395 delivers the industry's best performance combination of high efficiency, low input current distortion and high power factor. The 9395 operates at greater than 94 percent efficiency, reducing utility costs and extending battery runtimes. Higher system efficiency also results in cooler operating conditions, which reduces facility air conditioning cost, extends the life of UPS components, and increases overall reliability, availability, and performance. A new input circuit design within the 9395 keeps input current THD low and input power factor near unity without compromising overall efficiency. As a result, the UPS allows maximum transfer of power between the power source and the protected load and is exceptionally compatible with multiple power sources, especially auxiliary generators. On the output side, the ultra high-speed switching pulse width modulation (PWM) inverter enables the 9395 to provide its full rated power capability to the load whether the load power factor is 0.9 lagging, unity, or 0.9 leading.

The use of sustainable materials and highly efficient manufacturing technology results in dramatic savings in carbon footprint versus similar UPS products.

Measuring power performance: Efficiency, power factor, and THD

Power performance, which is measured by system efficiency, output power factor, and THD, is the foundation of the Eaton 9395. It is the UPS's robust combination of these three elements that make it stand out as the premier UPS in its class. The table below demonstrates how the 9395 with Energy Saver System compares to competitive UPS models. Most manufacturers must use input filters, which lower their efficiency rating. The 9395, on the other hand, does not require input filters to obtain excellent input THD.

As an example, a large data center (2.2 MVA) would realize the following savings by using a 9395 in Energy Saver System (ESS) compared to traditional N+1 systems:

- Additional energy savings: 2917 MW hours
- Additional carbon savings: 2523 tons
- Annual cost savings: \$315,708

EATON 9395 (WITH ESS) ANNUAL POWER SAVINGS VS. THE COMPETITION

Model	kVA rating	Full load annual power savings	Half load power savings	Cooling power savings at half load	Total savings at half load (power and cooling)
Eaton 9395	1100				
vs. Competitor A	1000	\$66,300	\$35,700	\$23,800	\$59,500
vs. Competitor B	1000	\$20,400	\$15,300	\$10,200	\$25,500

costs calculated at industry average of \$.10 per KWH

EATON 9395 POWER DENSITY VS. THE COMPETITION (N+2 SYSTEM)

Model	kVA rating	KW per sq. foot	Annual space cost savings (at \$1000 per sq. foot)
Eaton 9395	1100	25.5	
vs. Competitor A	1000	16.6	\$15,000
vs. Competitor B	1000	16.9	\$20,000

The importance of system efficiency

To demonstrate the importance of total system efficiency in relation to load level, the graph below shows how efficiency generally dips as load level decreases. In general, manufacturers list an optimal efficiency rating at full load. In reality, however, most three-phase UPSs operate in the range of 20—40% load. As a result, it is extremely important to evaluate the efficiency of a UPS at lighter loads as this graph depicts. Energy Saver System operates at 99% efficiency even at low load levels giving end users real energy savings.

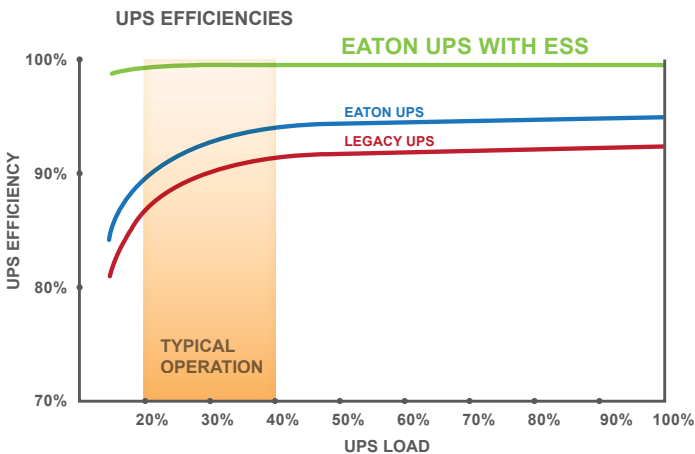

Easy Capacity Test

The 9395 has the unique ability to test its entire power train under full load stress without the requirement of an external load. With no load connected, the 9395 is able to test all of its power handling components, including the rectifier, inverter, contactors, fuses, power buses, cabling, batteries, bypass (static switch), magnetics, and filter capacitors. The net result

of this innovative load test is that there are no load banks to rent, no temporary load connections to make, and no wasted energy. Furthermore, the 9395 has the ability to test the upstream bypass input breaker (BIB), the rectifier input breaker (RIB), and all of the electrical cables between them. This load test feature can take the place of most traditional

load bank tests to save you time and money during startup and commissioning. Eaton field technicians are trained to use this load testing capability during a startup service to ensure optimum calibration and, maximum efficiency, and inherent redundancy. As a result, they can produce a report that verifies these tests and overall performance of the UPS. All

preventive maintenance visits included with PowerTrust Service Plans for the 9395 include this unique load testing feature to ensure that the UPS is operating optimally. It also validates the performance of an installed UPS and can simulate various operations and power transfers.

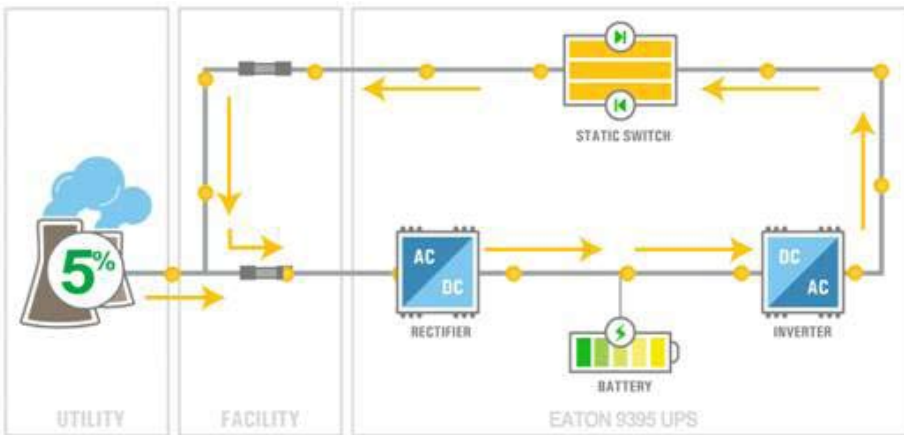

Easy Capacity Test Power Flow

Scalable, redundant architecture meets current and future requirements

The 9395 combines the reliability and redundancy of a multi-module UPS into an integrated, pre-wired solution. With a unique, flexible design that provides scalability, the UPS can adapt to future changes in load demands and new requirements for higher reliability without requiring the purchase of an additional UPS. For example, the 9395 UPS enables you to add a 275 kVA UPM in the field for N+1 redundancy or capacity.

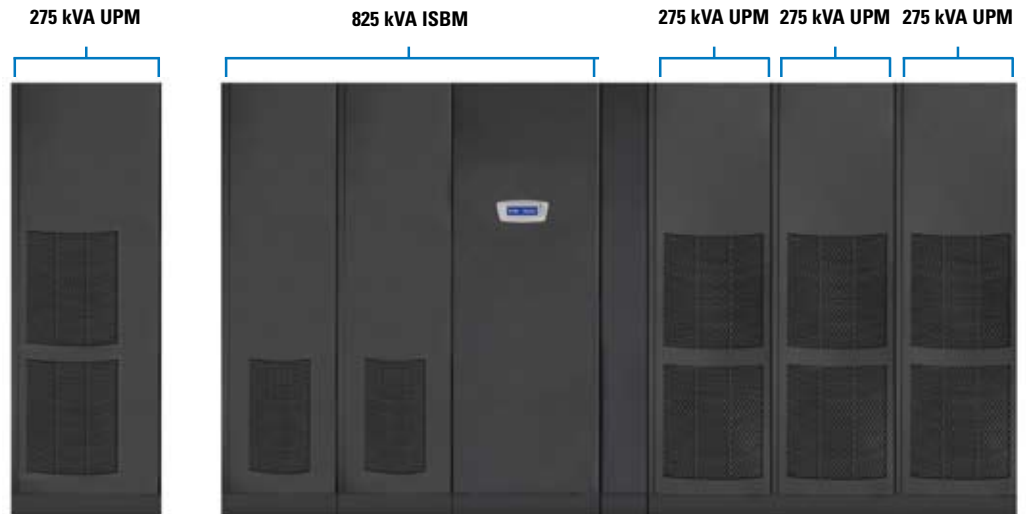

Eaton 9395 825 kVA

System Bypass Module: unparalleled flexibility for your parallel UPS system

Four decades of experience in paralleling large UPS systems is incorporated in this newest System Bypass Module (SBM) from Eaton. For use with multi-module paralleled 9395 systems, the switchgear enclosure encompasses a centralized static switch. It is orderable with either momentary or continuous duty rating, along with system-level circuit breakers for bypass, UPS system output, feedback protection and maintenance, or "wrap-around" bypass functions. Four ratings are available as standard: 1200A, 2000A, 3000A and 4000A. This

customizable cabinet features a 10 inch color LCD screen to display status for up to 32 of the UPM modules, and provides an intuitive user operation interface.

The touch sensitive SBM display shows a graphical view of the entire system one-line diagram, with intuitive controls and quick access to key information like battery time remaining, event/alarm history, system metering for kW and kVA, voltage, current, frequency, power factor and phase balance. The SBM also provides terminal connections for system-level building alarm inputs and relay outputs. To enhance flexibility, the

system controls/monitoring section may also be deployed in custom or third party switchgear, to ensure that the most reliable monitoring and user-friendly controls are included with alternative power circuit components.

The Eaton SBM incorporates the following hallmarks of Powerware Hot Sync paralleling technology, which has defined Eaton's most mission-critical UPS configurations for decades:

- Multiple UPS synchronization and load sharing accomplished without dependence inter-module wiring networks.

- Peer-to peer architecture which operates the parallel system without the need for master load share or master synchronization controls. The system operates with NO centralized control circuit.
- Control Area Network (CAN) bus architecture to ensure precise load sharing <3% at full system load.
- Designed with no single point failure in powertrain or control.



Eaton 10 inch LCD SBM screen

Concurrent maintenance: Higher availability

With 9395 redundant models, Eaton field technicians can completely isolate and service a redundant module while the other module carries the load—without going to bypass for service. The 9395 also features a completely front-accessible design and can be installed against walls or back to back in multi-module configuration. This service-friendly design enhances maximum uptime and availability.

Ease of installation

Traditional multi-module installations require up to three times the footprint for power modules and tie cabinets. In contrast, the 9395 is a completely integrated large system that incorporates multiple power modules and system switchgear on factory pre-wired bases. Since everything is pre-wired, cabling costs and installation time are significantly reduced.

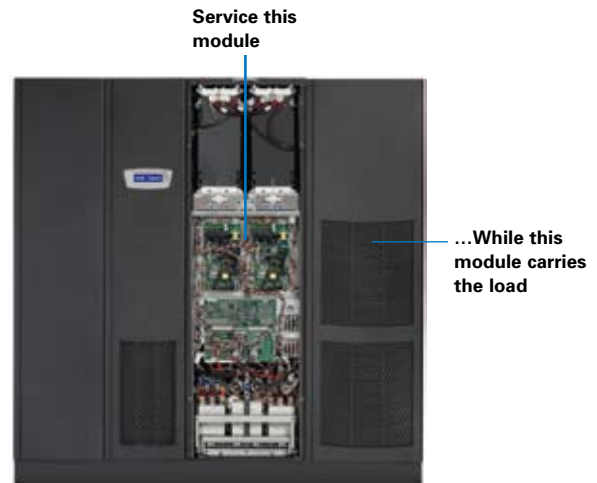

Eaton 9395 550 kVA

825 kVA N+1: Eaton 9395 vs. Competitor

Competitor Solution

125 sq. ft.

19,215 lb system weight*

Extensive site wiring

*Excluding batteries

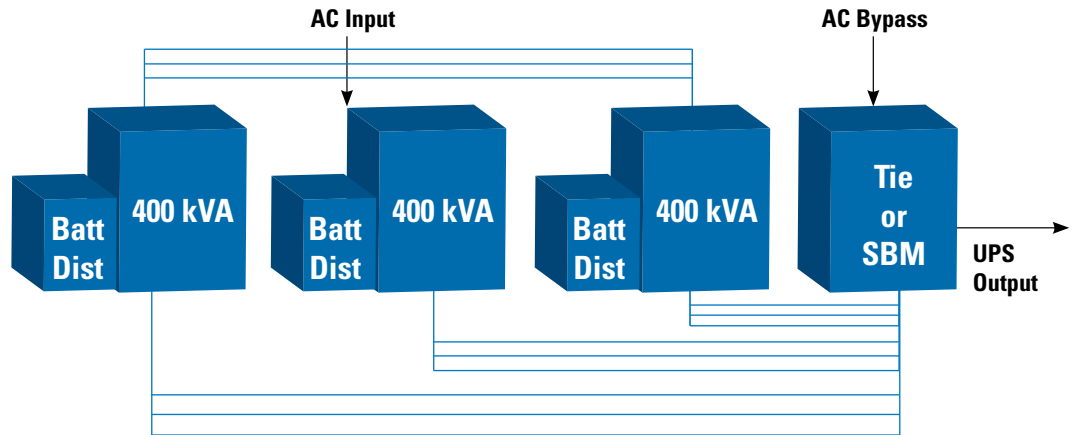

Eaton 9395 Solution

39 sq. ft.

6,365 lb system weight*

Minimal site wiring

*Excluding batteries

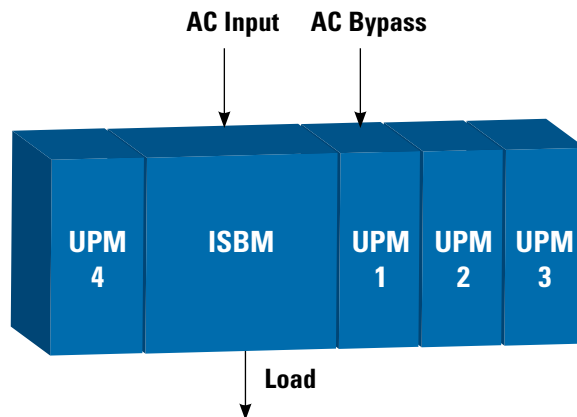

Greatly reduced footprint

The 9395 UPS offers the smallest footprint and lowest weight of any UPS in its class—50 to 60 percent less than competitive units. In fact, the 9395 fits a redundant design into the same footprint as a traditional, non-redundant UPS. The 9395's smaller footprint not only reduces your total cost of ownership, but also provides a UPS that is approximately half the weight of legacy and competitive systems. As a result, freight costs are much lower and the smaller size and weight of the UPS make it much easier to handle. In fact, the 9395 fits easily through all doors and can

be transported on freight elevators. Unlike some larger and heavier systems, there is no need to dismantle it to fit it on elevators or through doorways, which can cause significant delays and increase costs.

Minimized cabling requirements and expense

In an integrated system such as the 9395, multi-module systems arrive pre-wired with no need to perform costly and time-consuming inter-unit cabling for power and communications between modules and the system bypass unit. Considering the increasing cost for raw

materials such as copper, this savings can be significant. Cabling enters the 9395 UPS from either the top or bottom of the cabinet to provide easier and more flexible installation

Reliable Eaton components

The 9395 leverages reliable and proven electrical components manufactured by Eaton such as Cutler-Hammer circuit breakers and contactors.

Eaton's total PowerChain Management solution

Eaton views your power system as a strategic asset—an approach we call PowerChain Management®. Eaton's PowerChain Management solutions can help transform complicated power systems into a single, integrated system easily visible and manageable as a strategic business asset, providing a significant competitive advantage.

If your company is like most, its power system was built over time. As the organization's needs changed, additional equipment was likely piece-mealed into the system, with a circuit breaker added here and a transformer replaced there. The result can be a power system that is a complicated mixture of old and new equipment from several different manufacturers. Because there is no common means of communicating across this varied equipment, gathering data across the enterprise can be quite challenging.

Enhance your business visibility to see the entire picture

The complexity of gathering data among various devices makes it difficult to get a clear picture of what's happening inside your power system, which decreases your ability to manage your power system effectively. Consequently, business results suffer, because your enterprise depends on its power system.

Eaton's Power Xpert® Architecture, the backbone of our PowerChain Management solutions, enables you to monitor much more than your 9395 UPS; it transforms your power system into an integrated, agile system that delivers real competitive advantages. With the software and hardware components of Power Xpert Architecture, you can monitor, control, and manage your complete power system effectively and efficiently, including PDUs, batteries and other critical equipment. Using a simple, Web-based interface, the varied elements of your power system are integrated into a single view, with the ability to easily monitor the availability and reliability of electrical power, lower energy costs, extend equipment life, and more.

Optimize your power system

PowerChain Management can also help you manage your power system for peak performance by integrating and optimizing your power assets and ensuring that they align with your business goals.

Once your power system is linked to an Ethernet network via the Power Xpert Architecture, you can connect to and share information with a variety of applications, such as the building management system monitoring your HVAC equipment, or your enterprise accounting system. Power Xpert Architecture's open standards and scalable approach make it easy for your power system to grow and adapt to a rapidly changing environment.

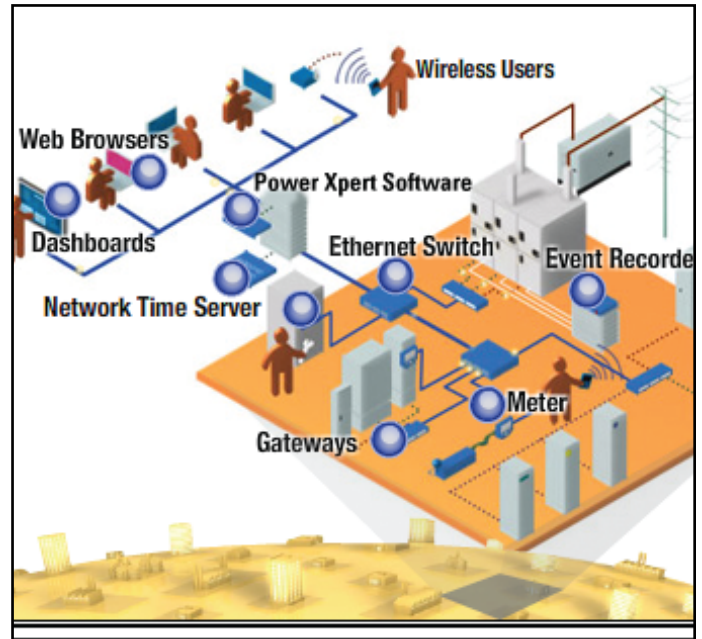

Eaton delivers a new level of confidence

The culmination of 40 years of R&D excellence, the new Eaton 9395 UPS delivers the utmost in confidence—confidence that your organization's critical systems are protected by the most reliable, efficient, and full-featured protection solution available. Eaton will be there with you long term, with premium warranty coverage and expert technical support. **To find out more about the 9395 UPS, visit our Web site at www.powerware.com/9395 or contact us at 1.800.356.5794.**



The ConnectUPS-X Web/SNMP Card allows you to connect your 9395 directly to the Ethernet network and the Internet. This unique solution allows you to conveniently monitor and manage your UPS with a standard Web browser. The ConnectUPS Card is also used to take advantage of Eaton's 7x24 eNotify Remote Monitoring Service.

Core components



Eaton 9395 825 kVA N+1 or 1100 kVA capacity

A closer look inside the Eaton 9395

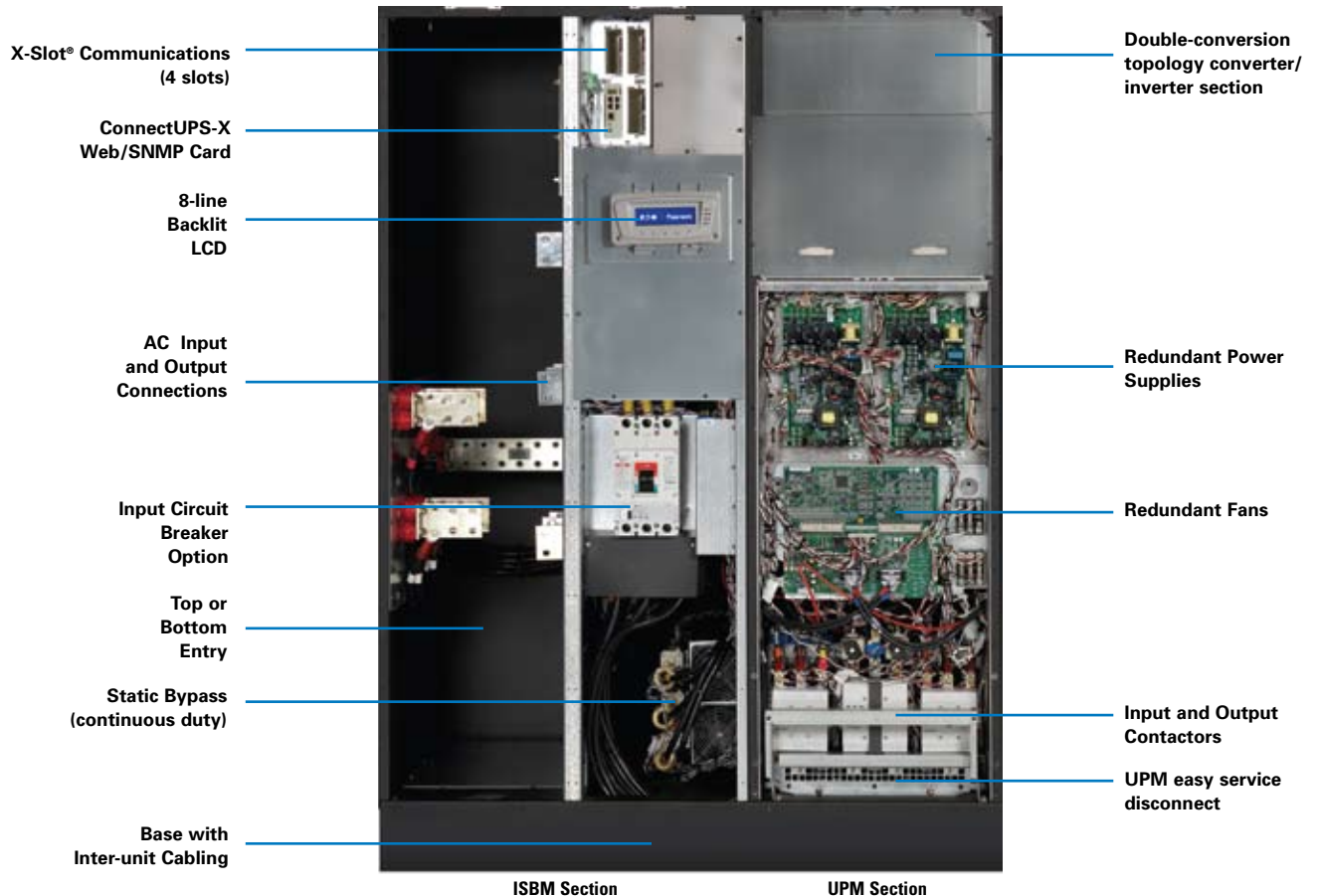

Eaton 9395 550 kVA

Technical specifications²

UPS rating (0.9 power factor)

kVA	225	275	450	500	550	650	750	825	1000	1100
kW	202	250	405	450	500	585	675	750	900	1000

General characteristics

Efficiency	>94%
Parallel capability	4 distributed, 32 with SBM
Max modules per size	Up to 3 modules, 550 kVA, up to 4 modules, 825/1100 kVA
Audible noise	<76dBA @ 1 meter
Altitude (max)	2000m at 40°C (104°F)
N+1 redundancy capable	Yes
Field upgradeable	Yes
System bypass module	Included

Input characteristics

Voltage	480V standard; and 400V available
Voltage range	+10% / -15%
Frequency range	45-65 Hz
Power factor	0.99 (minimum)
Input current distortion	<3.5% (no input filter required)
Soft start capability	Yes
Internal backfeed protection	Yes

Output characteristics

Voltage	480V standard; and 400V available
Regulation	±1%
Inverter	PWM with IGBT switching
Voltage THD	<2% (100% linear load); <5% (non-linear load)
Load power factor range	Up to a .9 power factor leading without derating

Battery

Battery types	VRLA, AGM, Gel, Wet Cell
Battery voltage	480V
Temperature compensation	Optional
Charging method	ABM technology or Float, Selectable

Dimensions and weights

225 kVA, 275 kVA	52.4" w x 32.7" d x 73.6" h	1786 lb
225 kVA redundant, 275 kVA redundant	73.7" w x 32.7" d x 73.6" h	2875 lb
450, 500, 550 kVA	73.7" w x 32.7" d x 73.6" h	2977 lb
450, 550 kVA redundant	103" w x 32.7" d x 73.6" h	4153 lb
Field upgrade module, 225 or 275 kVA	30" w x 32.7" d x 73.6" h	1176 lb
650, 750, 825 kVA	140.9" w x 32.7" d x 73.7" h	5065 lb
650, 750, 825 kVA +1 redundant	170.2" w x 32.7" d x 73.7" h	6365 lb
1000, 1100 kVA	170.2" w x 32.7" d x 73.7" h	6525 lb

UNITED STATES
8609 Six Forks Road
Raleigh, NC 27615 U.S.A.
Toll Free: 1.800.356.5794
or 919.872.3020

www.eaton.com/powerquality

CANADA
Ontario: 416.798.0112
Toll free: 1.800.461.9166

LATIN AMERICA
South Cone: 54.11.4124.4000
Brazil: 55.11.3616.8500
Andean & Caribbean:
1.949.452.9610
Mexico & Central America:
52.55.9000.5252

General characteristics

Control panel (LCD)	8 lines x 40 characters
Battery startup	Standard
Frequency conversion	Standard
Multi-language	Standard
Building alarm inputs	5 (galvanic isolated)

Options

External maintenance bypass	
Powerware PDU, RPP, and STS	
Maintenance bypass module, matching cabinet, 2/3/4 breaker	
DC disconnects	
65 or 100 kAIC input breakers	

Certifications

Safety	UL1778, cUL
EMC	IEC 62040-2, EN50091 Class A (restricted access)

eNotify remote monitoring

7x24 remote monitoring of UPS and battery alarms, daily heartbeat check and monthly report. eNotify requires the ConnectUPS-X Web/SNMP Card and Environmental Monitoring Probe.

Communications

Software compatibility: Power Xpert
Communications cards: Four communication bays standard. The following connectivity options can be installed at any time:

- ConnectUPS-X Web/SNMP Card (included)
- ModBus RTU card
- AS/400 Relay card
- Industrial Relay card
- Powerware HotSync CAN Bridge card
- Environmental Monitoring Probe (included)
- Modem card

Remote inputs/outputs: Five building alarm inputs and one summary alarm contact (5A @ 120V) standard

Remote monitor panel: Eight backlit status indicator lamps plus an audible horn

1. Due to continuing improvements, specifications are subject to change without notice.
2. Please refer to Eaton 9395 technical documents for specific configuration guidelines and features.



EUROPE/MIDDLE EAST/AFRICA

Denmark: 45.3686.7910
Finland: 358.94.52.661
France: 33.1.6012.7400
Germany: 49.0.7841.604.0
Italy: 39.02.66.04.05.40
Norway: 47.23.03.65.50
Portugal: 55.11.3616.8500
Sweden: 46.8.598.940.00
United Kingdom: 44.1753.608.700

ASIA PACIFIC

Australia: 61.2.9693.9366
New Zealand: 64.0.3.343.3314
China: 86.21.6361.5599
HK/Korea/Taiwan: 852.2745.6682
India: 91.11.4223.2300
Singapore/SEA: 65.6825.1668

Eaton, PowerChain Management is a trade name, trademark, and/or service mark of Eaton Corporation or its subsidiaries and affiliates.

All other trademarks are property of their respective owners.

©2010 Eaton Corporation
All Rights Reserved
Printed in USA
9395FXA
February 2010