

PowerChain Management solutions

# Eaton ePDU Data Center Product Catalog

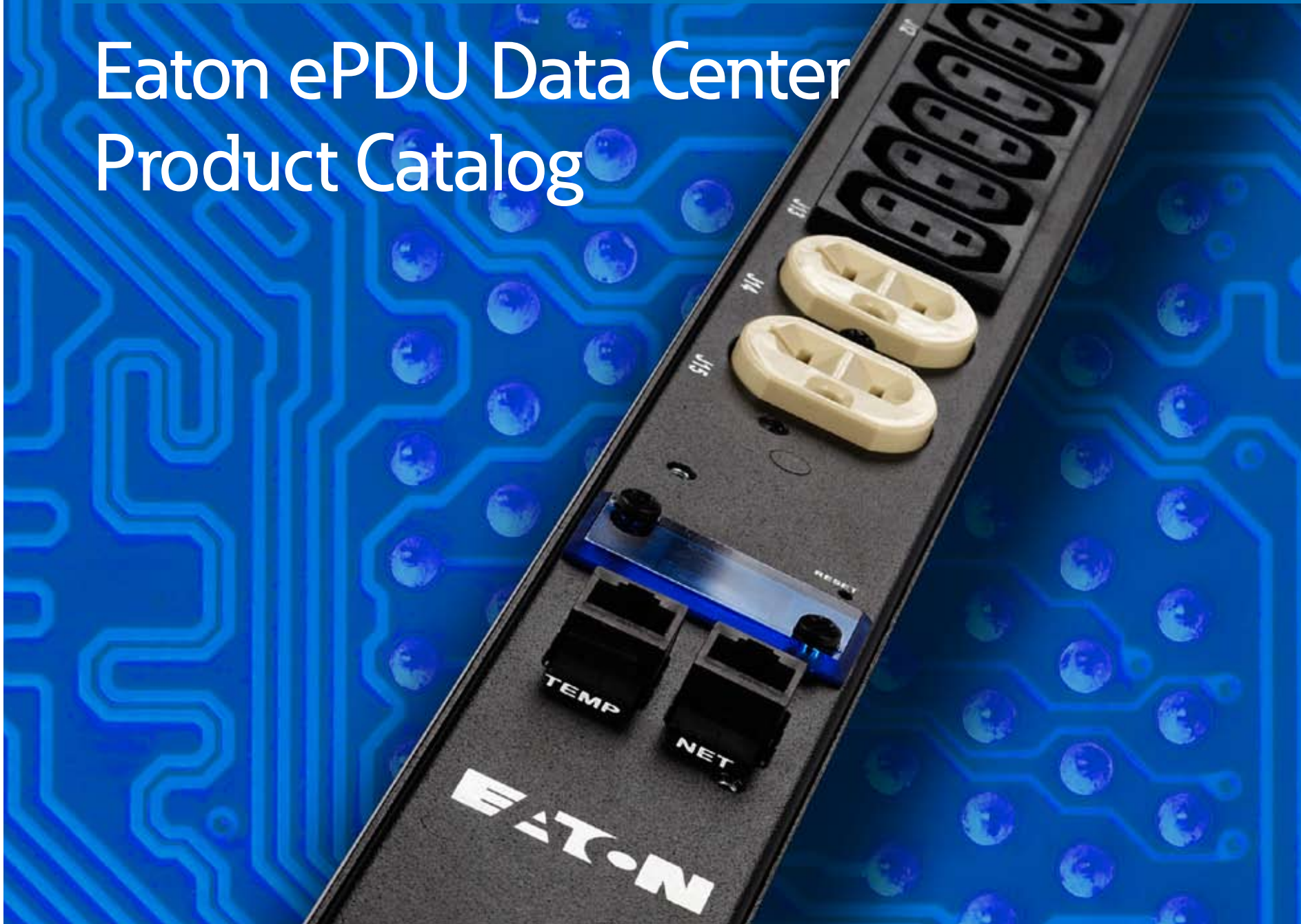

**EATON**  
*Powering Business Worldwide*

Switch  N to Eaton.



## Table of contents

<b>Overview &amp; Functionalities</b> .....	4
<b>Choosing Power Density</b> .....	5
<b>ePDU Technologies</b> .....	6
<b>Understanding ePDU Technologies</b> .....	7
<b>ePDU units</b> .....	9
<b>ePDU Value Line</b> .....	8
Horizontal Mount.....	8
Vertical Mount.....	9
<b>FlexPDUs</b> .....	10
<b>Understanding Catalog Numbers</b> .....	11
<b>Standard Density</b> .....	12
Horizontal Mount.....	12
Vertical Mount.....	12
<b>High Density</b> .....	14
Horizontal Mount.....	14
Vertical Mount.....	15
<b>Ultra High Density</b> .....	18
Horizontal Mount.....	18
Vertical Mount.....	18
<b>eATS Units</b> .....	20
<b>V55 Ultra High Density ePDU</b> .....	22
<b>Rack Power Module</b> .....	23
<b>Intelligent Power Manager</b> .....	24
<b>ePDU Plugs and Receptacles</b> .....	25
<b>Power Cables and Accessories</b> .....	26
<b>Space-saving Mounting Options</b> .....	27

## ePDU® Features

- **Intelligent Power® Distribution**
- **Designed specifically for data center IT environments**
- **Rackmount industrial grade**
- **Provide manageability and customizable enclosure control**
- **Multiple configurations of features and functions**
- **Domestic and international configurations**
- **Products meet global safety standards**
- **Certified and Agency approved systems**
- **Mission Critical 24/7/365 reliability**

## Broad Product Portfolio

Eaton offers the largest selection of enclosure power distribution units available on the market. This complete suite of power products is designed specifically to help data center IT managers meet their rapidly escalating power requirements.

## 24/7 Reliability through Circuit Breakers or Individual Outlet Fusing

ePDUs use individual UL-rated branch circuit breakers that protect load segments (outlet groups), ensuring that an overloaded circuit does not affect other load segments, therefore increasing reliability. Typically, circuit breakers have flat rockers or are fully shrouded to prevent accidental on/off operation. Eaton ePDUs give the option of circuit breaker or individual outlet fusing, giving you options for branch circuit protection or for outlets to be individually protected.

## High Density Power Solutions

Do you have power hungry racks of IT equipment, such as blade servers and switches? Are you running out of power capacity before rack space in your enclosure? Everyday higher levels of performance are expected without sacrificing reliability. Eaton offers a full line of high power density solutions to meet your needs. We offer both rackmount and vertical mount three-phase ePDUs ranging from 50A, 60A to even 80A input capacities. These sophisticated units allow an entire rack of equipment to be powered from a single power cord input.

## How to Choose Your Power Density

With Eaton ePDUs, you can choose units based on the amount of power you need:

### Standard Density (0-5kW) (page 12)

Our Standard Density ePDUs have up to eight 1U/2U servers or peripherals, such as network switches, environmental monitors, KVM devices and rack accessories.

### High Density (5-10kW) (page 14)

Our High Density ePDUs have up to 25 1U/2U servers or three blade server chassis, offering up to 45 receptacles in multiple form factors.

### Ultra High Density (10+kW) (page 18)

Our Ultra High Density ePDUs are for racks with up to four blade server chassis and other power-hungry pieces of IT equipment.

## Rugged Design for Optimal Performance and Quick Installation

ePDUs are designed to meet global safety standards. These units are engineered with rugged construction, have flexible mounting options, and multiple features ensuring the highest quality and customer satisfaction. Eaton engineers unique solutions for the most power intense environments.

## Eaton makes ePDU product configuration as easy as 1, 2, 3...

On [epdu.com](http://epdu.com), Eaton's product configuration wizard is a simple interface that allows the customer to search over 1,000 products for the perfect solution. Customers can explore features, benefits and learn basic fundamentals of ePDUs, as well as interact with the live demo. This site asks the customer three very key questions about their power needs:

- 1. How much power do you need?**
- 2. What functionality do you need?**
- 3. What inputs and outputs do you need?**

The live demo will allow customers to walk through their requirements and pick from specific ePDU inventory based on their choices. Making the right decisions from the start can make a difference in the dependability and efficiency of an infrastructure. If customers need help or have questions with their selection they can use the live chat icon, or call one of the listed support numbers.

## ePDU technologies

Eaton's ePDU s power densities and technologies satisfy the demand of every data center. Eaton ePDUs offer single and dual chassis, five technology options, the broadest power range in the market and the ability to manufacture custom ePDUs, and allow arrangement of outlets (number and type) for every region.

Eaton ePDUs are distinguished for their quality, dependability and versatility. All products are designed for a specific application with an emphasis on safety and reliability. The Eaton line includes an extensive range of vertical, Zero U products, which do not occupy server space in racks, as well as 1U and 2U formats. Environmental Monitoring options are also available.

Feature	Basic (BA)	Monitored Network (MI)	Advanced Monitored (AM)	Switched (SW)	Monitored (MO)
Rugged Construction	x	x	x	x	x
Horizontal Products	x	x			x
Vertical Products	x	x	x	x	
Local Current Display		x	x	x	
Current Monitoring Type		<b>Section</b>	<b>Outlet</b>	<b>Section</b>	
Voltage Monitoring			x	x	
Serial Interface				x	x
Ethernet Interface		x	x	x	
Environmental Sensors			x	x	

Refer to table above throughout catalog for ePDU functionalities.

## TopSeller Program



This icon represents our topselling ePDUs, which are stocked for high availability and will ship next day. Nearly every ePDU in this catalog is a TopSeller and you will find this icon associated with a specific line.

## Why monitor?

The unique monitoring function of Eaton ePDUs allows customers to remotely monitor the current draw of individual outlets via Ethernet. This, combined with state-of-the-art software, allows the user to aggregate the information from hundreds of ePDUs in one location. All monitored ePDUs also include the Easy-Read digital LED ammeter for easy start-up and provisioning of servers. This feature ensures easy management and monitoring for current requirements and future expansion.



## Key features & benefits

- All circuit-level and ePDU-level information can be accessed worldwide
- Intelligent Power Manager software from Eaton delivers a global view across your ePDUs from any PC or server
- All warnings and alarms are sent remotely

## Advanced Monitoring



### Advanced Monitored (AM) – Current Monitoring Per Outlet (available in custom units only)

Designed for high-density, mission critical server applications, the Advanced Monitored ePDU provides maximum power for both standard and blade servers. Employing multiple configurations, Easy-Read digital ammeter and remote power management with clearly labeled circuits, this model assures easy management and monitoring for current requirements and allows for future expansion.

### Key features:

- Remote individual outlet level monitoring
- High-density configurations reduce enclosure space requirement
- Fuse-less design significantly reduces reset time
- UL Listed (UL489) branch circuit breakers meet UL60950-1 Edition requirements
- Easy read digital ammeter reduces local monitoring time (auto scroll capability)
- True RMS ammeter provides accurate power measurement
- Multi-purpose mounting improves installation flexibility
- Isolation hardware improves product grounding
- High-grade components increases product reliability and fault tolerance
- Clearly labeled circuits simplify load balancing



## Value ePDU Line

Eaton's ePDU Value line is designed to provide the highest reliability and quality for the most critical power loads. Light weight and easy to mount, these power distribution units are cost effective solutions to meet all business needs.

## Horizontal Mounts

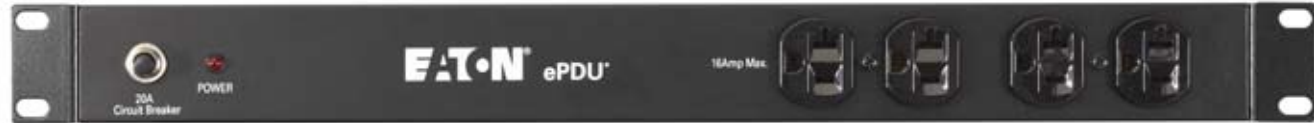

ePBZ99

Catalog Number	Style	Input Plug	Breaker	Max kW	Function	Cord (ft)	Orientation	Receptacles	Dimensions (W x H x D, in)
ePBZ99	ePBZ99	L5-20	20A (1)	1.9	BA	9	1U	5-20 (12) 8 front/4 back	17 x 1.72 x 2.4



ePBZ88

Catalog Number	Style	Input Plug	Breaker	Max kW	Function	Cord (ft)	Orientation	Receptacles	Dimensions (W x H x D, in)
ePBZ88	ePBZ88	C20	None	3.3	BA	9	1U	IEC320-C13 (10), IEC320-C19 (2)	17 x 1.72 x 2.4



ePBZ95

Catalog Number	Style	Input Plug	Breaker	Max kW	Function	Cord (ft)	Orientation	Receptacles	Dimensions (W x H x D, in)
ePBZ95	ePBZ95	L6-20	None	3.3	BA	9	1U	IEC320-C13 (12), IEC320-C19 (1)	17 x 1.72 x 2.4



ePBZ94

Catalog Number	Style	Input Plug	Breaker	Max kW	Function	Cord (ft)	Orientation	Receptacles	Dimensions (W x H x D, in)
ePBZ94	ePBZ94	L6-30	20A (2)	5.0	BA	9	1U	IEC320-C19 (6)	17 x 1.72 x 2.4
ePBZ91*	ePBZ91	L6-30	20A (2)	5.0	BA	9	1U	IEC320-C13 (12)	19 x 1.75 x 2.4

\*Available July 15, 2010



## Vertical Mounts



ePBZ98

Catalog Number	Style	Input Plug	Breaker	Max kW	Function	Cord (ft)	Orientation	Receptacles	Dimensions (W x H x D, in)
ePBZ98	ePBZ98	5-15	15A	1.4	BA	9	0U	5-15 (18)	1.5 x 48 x 1.5



ePBZ97

Catalog Number	Style	Input Plug	Breaker	Max kW	Function	Cord (ft)	Orientation	Receptacles	Dimensions (W x H x D, in)
ePBZ97	ePBZ97	5-20	20A (1)	1.9	BA	9	0U	5-20 (24)	1.5 x 60 x 1.5
ePBZ96	ePBZ96	L5-20	20A (1)	1.9	BA	9	0U	5-20 (24)	1.5 x 60 x 1.5
ePBZ90*	ePBZ90	L5-30	20A (2)	1.9	BA	9	0U	5-20 (24)	1.5 x 60 x 1.5

\*Available July 15, 2010



ePBZ89

Catalog Number	Style	Input Plug	Breaker	Max kW	Function	Cord (ft)	Orientation	Receptacles	Dimensions (W x H x D, in)
ePBZ89	ePBZ89	C14	None	2.7	BA	9	0U	IEC320-C13 (16)	1.9 x 25 x 2.2



ePBZ93

Catalog Number	Style	Input Plug	Breaker	Max kW	Function	Cord (ft)	Orientation	Receptacles	Dimensions (W x H x D, in)
ePBZ87*	ePBZ87	C14	20A (1)	3.3	BA	9	0U	IEC320-C13 (16)	1.9 x 28 x 2.2
ePBZ92	ePBZ92	L6-30	20A (2)	5.0	BA	9	0U	IEC320-C13 (20), IEC320-C19 (4)	1.9 x 40 x 2.2
ePBZ93	ePBZ93	L6-20	20A (1)	3.3	BA	9	0U	IEC320-C13 (20), IEC320-C19 (4)	1.9 x 40 x 2.2

\*Available July 15, 2010



## FlexPDUs

These units are designed to increase power distribution from a single UPS and provide more flexibility. The Flex products have a three-foot input cord, which allow the units to be mounted in close proximity to a single phase UPS, and provide multiple outlet configurations in a small chassis.



EFLX1500R-PDU1U

Catalog Number	Style	Input Plug	Breaker	Max kW	Function	Cord (ft)	Orientation	Receptacles	Dimensions (W x H x D, in)
EFLX1500R-PDU1U	58015	5-15	None	1.4	BA	3	1U	5-15 (12)	19 x 1.75 x 2.4
EFLX2000R-PDU1U	58020	5-20	None	1.9	BA	3	1U	5-20 (12)	19 x 1.75 x 2.4



EFLX2000R-PDU1UL

Catalog Number	Style	Input Plug	Breaker	Max kW	Function	Cord (ft)	Orientation	Receptacles	Dimensions (W x H x D, in)
EFLX2000R-PDU1UL	58021	5-20	None	1.9	BA	3	1U	L5-20 (5)	19 x 1.75 x 3



EFLX13000R-PDU1UIEC

Catalog Number	Style	Input Plug	Breaker	Max kW	Function	Cord (ft)	Orientation	Receptacles	Dimensions (W x H x D, in)
EFLX13000R-PDU1UIEC	68438	C20 Inlet	20A (2)	3.3	BA	3	1U	IEC320-C13 (12), IEC320-C19 (1)	19 x 3.5 x 2.4

Includes C19 to C14 and C19 to C20 jumper cables

## Eaton Catalog Number Ordering Instructions for ePDUs

Eaton is now employing the use of smart part numbers to help our customers locate and design the product that fits their needs and makes ordering a snap. Follow the example below to see how to easily select your product's features and find the catalog number for your order.

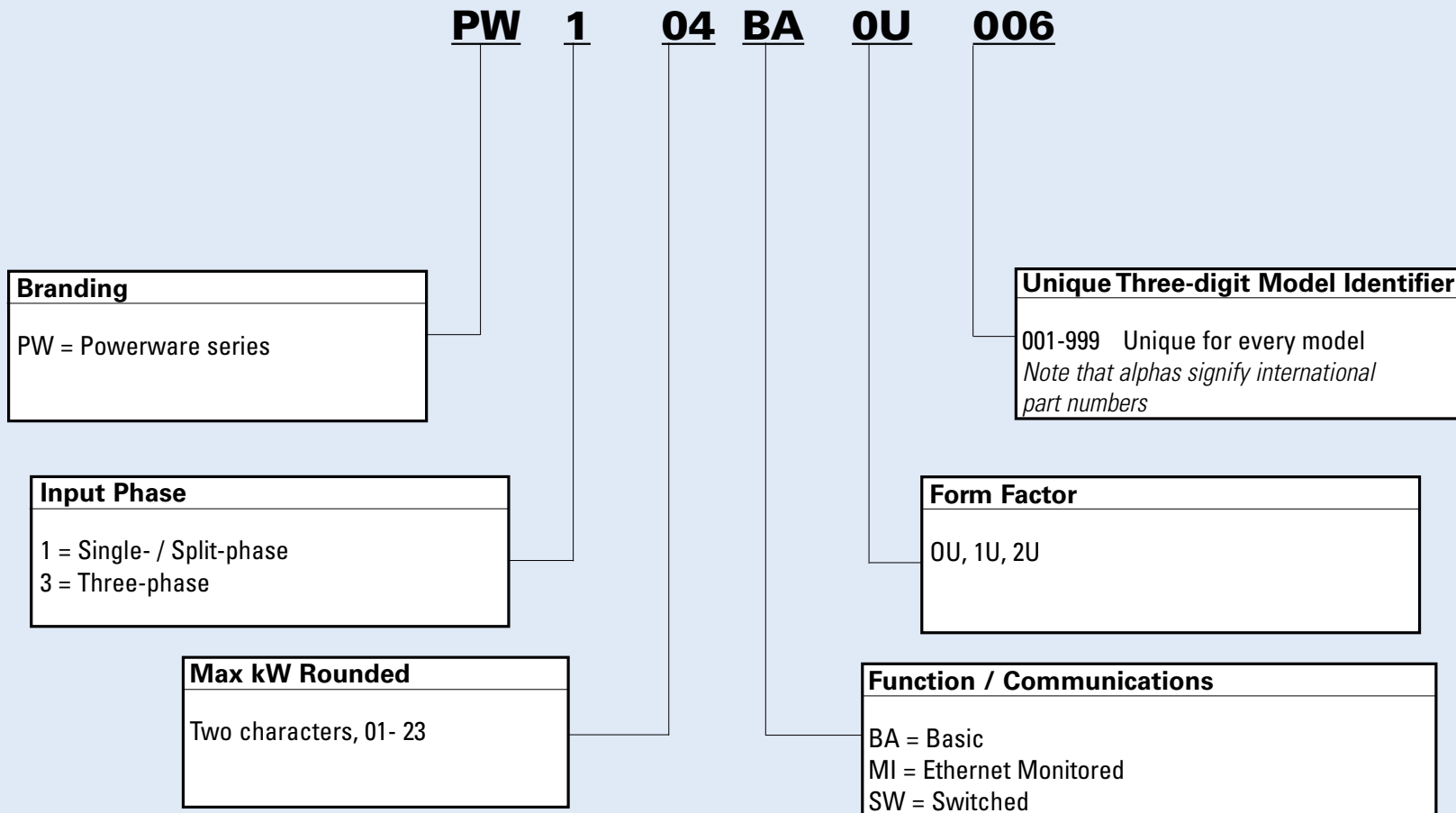



## Standard Density ePDUs

Intended to power up to eight 1U/2U servers or peripherals such as network switches, environmental monitors, KVM devices, rack accessories and legacy equipment that require 120V only. These ePDUs are up to 5kW and can have up to 24 outlets.

### Horizontal Mounts



PW101BA1U140

Catalog Number	Style	Input Plug	Breaker	Max kW	Function	Cord (ft)	Orientation	Receptacles	Dimensions (W x H x D, in)
PW101BA1U140	T982A1-N-SS-009	5-15	15A (1)	1.4	BA	9	1U	5-15 (12)	19 x 1.75 x 7
PW101MI1U221	T982A1-N-SS-109	5-15	15A (1)	1.4	MI	9	1U	5-15 (12)	19 x 1.75 x 7



PW102MI1U160

Catalog Number	Style	Input Plug	Breaker	Max kW	Function	Cord (ft)	Orientation	Receptacles	Dimensions (W x H x D, in)
PW102BA1U158	T982A2-N-SS-009	5-20	20A (1)	1.9	BA	9	1U	5-20 (12)	19 x 1.75 x 7
PW102BA1U159	T982A2-N-SL-009	L5-20	20A (1)	1.9	BA	9	1U	5-20 (12)	19 x 1.75 x 7
PW102MI1U160	T982A2-N-SL-109	L5-20	20A (1)	1.9	MI	9	1U	5-20 (12)	19 x 1.75 x 7
PW103BA1U190	T982C2-N-SL-009	L5-30	20A (2)	2.9	BA	9	1U	5-20 (12)	19 x 1.75 x 7
PW103MI1U161	T982C2-N-SL-109	L5-30	20A (2)	2.9	MI	9	1U	5-20 (12)	19 x 1.75 x 7



PW103MI1U162

Catalog Number	Style	Input Plug	Breaker	Max kW	Function	Cord (ft)	Orientation	Receptacles	Dimensions (W x H x D, in)
PW103BA1U191	T982B3-N-SL-009	L6-20	20A (1)	3.3	BA	9	1U	IEC320-C13 (12)	19 x 1.75 x 7
PW103BA1U191	T982B3-N-SL-009	L6-20	20A (1)	3.3	BA	9	1U	IEC320-C13 (12)	19 x 1.75 x 7
PW103MI1U162	T982B3-N-SL-109	L6-20	20A (1)	3.3	MI	9	1U	IEC320-C13 (12)	19 x 1.75 x 7

### Vertical Mounts



PW101SW0U224

Catalog Number	Style	Input Plug	Breaker	Max kW	Function	Cord (ft)	Orientation	Receptacles	Dimensions (W x H x D, in)
PW101MI0U233	V70NA1-N-SS-109	5-15	None	1.4	MI	9	0U	5-15 (24)	1.89 x 66 x 2.0
PW101SW0U224	IPV70A1-EP1-09S	5-15	None	1.4	SW	9	0U	5-15 (24)	1.89 x 66 x 2.0



*PW102SW0U151*

Catalog Number	Style	Input Plug	Breaker	Max kW	Function	Cord (ft)	Orientation	Receptacles	Dimensions (W x H x D, in)
PW102MI0U234	V70NA2-N-SS-109	5-20	None	1.9	MI	9	0U	5-20 (24)	1.89 x 66 x 2.0
PW102MI0U235	V70NA2-N-SL-109	L5-20	None	1.9	MI	9	0U	5-20 (24)	1.89 x 66 x 2.0
PW102SW0U151	IPV70A5-EP1-09L	L5-20	None	1.9	SW	9	0U	5-15 (24)	1.89 x 66 x 2.0
PW103MI0U236	V70BC1-N-SL-109	L5-30	15A (2)	2.9	MI	9	0U	5-15 (24)	1.89 x 66 x 2.0
PW103BA0U257	V70BC2-N-SL-009	L5-30	20A (2)	2.9	BA	9'	0U	5-20 (24)	1.89 x 66 x 2.0



*PW103SW0U152*

Catalog Number	Style	Input Plug	Breaker	Max kW	Function	Cord (ft)	Orientation	Receptacles	Dimensions (W x H x D, in)
PW103SW0U152	IPV70C5-EP1-09L	L5-30	15A (2)	2.9	SW	9	0U	5-15 (16)	1.89 x 66 x 2.0



*PW103BA0U237*

Catalog Number	Style	Input Plug	Breaker	Max kW	Function	Cord (ft)	Orientation	Receptacles	Dimensions (W x H x D, in)
PW103BA0U237	V70NB4-N-SL-009	L6-20	None	3.3	BA	9	0U	IEC320-C13 (24), IEC320-C19 (4)	1.89 x 66 x 2.0
PW103MI0U238	V70NB4-N-SL-109	L6-20	None	3.3	MI	9	0U	IEC320-C13 (24), IEC320-C19 (4)	1.89 x 66 x 2.0



*PW103SW0U153*

Catalog Number	Style	Input Plug	Breaker	Max kW	Function	Cord (ft)	Orientation	Receptacles	Dimensions (W x H x D)
PW103SW0U153	IPV70B2-EP1-10L	L6-20	None	3.3	SW	10	0U	IEC320-C13 (24)	1.89 x 66 x 2.0



## High Density ePDUs

Intended to power up to 25 1U/2U servers or three blade server chassis, offering up to 45 receptacles in multiple form factors. Most ePDUs are equipped with local current meter and IP monitoring capability to facilitate load balancing and prevent circuit overloads.

### Horizontal Mounts



*PW105BA1U163*

Catalog Number	Style	Input Plug	Breaker	Max kW	Function	Cord (ft)	Orientation	Receptacles	Dimensions (W x H x D, in)
<a href="#">PW105BA1U163</a>	<a href="#">T982F3-N-SL-009</a>	L6-30	15A (2)	5.0	<b>BA</b>	9	1U	IEC320-C13 (12)	19 x 1.75 x 7
<a href="#">PW105MI1U164</a>	<a href="#">T982F3-N-SL-109</a>	L6-30	15A (2)	5.0	<b>MI</b>	9	1U	IEC320-C13 (12)	19 x 1.75 x 7



*PW105MI1U165*

Catalog Number	Style	Input Plug	Breaker	Max kW	Function	Cord (ft)	Orientation	Receptacles	Dimensions (W x H x D, in)
<a href="#">PW105BA1U192</a>	<a href="#">T982F4-N-SL-009</a>	L6-30	20A (2)	5.0	<b>BA</b>	9	1U	IEC320-C13 (6), IEC320-C19 (4)	19 x 1.75 x 7
<a href="#">PW105MI1U165</a>	<a href="#">T982F4-N-SL-109</a>	L6-30	20A (2)	5.0	<b>MI</b>	9	1U	IEC320-C13 (6), IEC320-C19 (4)	19 x 1.75 x 7



*PW105SW2U223*

Catalog Number	Style	Input Plug	Breaker	Max kW	Function	Cord (ft)	Orientation	Receptacles	Dimensions (W x H x D, in)
<a href="#">PW105SW2U223</a>	<a href="#">IPC36F4N2USW09L</a>	L6-30	20A (2)	5.0	<b>SW</b>	9	2U	IEC320-C13 (20), IEC320-C19 (4)	19 x 3.5 x 9.5

## Vertical Mounts



PW105BA0U239

Catalog Number	Style	Input Plug	Breaker	Max kW	Function	Cord (ft)	Orientation	Receptacles	Dimensions (W x H x D, in)
PW105BA0U239	V70BF5-N-SL-009	L6-30	20A (2)	5.0	BA	9	OU	IEC320-C13 (24), IEC320-C19 (4)	1.89 x 66 x 2.0
PW105MI0U240	V70BF5-N-SL-109	L6-30	20A (2)	5.0	MI	9	OU	IEC320-C13 (24), IEC320-C19 (4)	1.89 x 66 x 2.0



PW105SW0U154

Catalog Number	Style	Input Plug	Breaker	Max kW	Function	Cord (ft)	Orientation	Receptacles	Dimensions (W x H x D, in)
PW105SW0U154	IPV70F3-EP1-09L	L6-30	20A (2)	5.0	SW	9	OU	IEC320-C13 (16)	1.89 x 66 x 2.0



PW105MI0U255

Catalog Number	Style	Input Plug	Breaker	Max kW	Function	Cord (ft)	Orientation	Receptacles	Dimensions (W x H x D, in)
PW105MI0U255	V70BJ3-N-SL-109	L14-30	20A (2)	5.0	MI	9	OU	IEC320-C13 (24), IEC320-C19 (4), 5-20(4)	1.89 x 66 x 2.0



PW306BA0U241

Catalog Number	Style	Input Plug	Breaker	Max kW	Function	Cord (ft)	Orientation	Receptacles	Dimensions (W x H x D, in)
PW306BA0U241*	VPC2864-A2-3846	L21-20	None	5.8	BA	9	OU	5-20 (30)	1.89 x 66 x 2.0
PW306MI0U242*	VPC2864-A2-3847	L21-20	None	5.8	MI	9	OU	5-20 (30)	1.89 x 66 x 2.0

\*Available July 15, 2010

## Vertical Mounts



PW309MI0U248

Catalog Number	Style	Input Plug	Breaker	Max kW	Function	Cord (ft)	Orientation	Receptacles	Dimensions (W x H x D, in)
PW306MI0U243*	VPC2864-3848	L21-20	None	5.8	MI	9	0U	IEC320-C13 (24), IEC320-C19 (3), 5-20(6)	1.89 x 66 x 2.0
PW309MI0U248*	VPC2864-3849	L21-30	20A (3)	8.6	MI	9	0U	IEC320-C13 (24), IEC320-C19 (3), 5-20(6)	1.89 x 66 x 2.0

\*Available July 15, 2010



PW306BA0U244

Catalog Number	Style	Input Plug	Breaker	Max kW	Function	Cord (ft)	Orientation	Receptacles	Dimensions (W x H x D, in)
PW306BA0U244*	VPC2864-3850	L21-20	None	5.8	BA	9	0U	IEC320-C13 (36), IEC320-C19 (6)	1.89 x 66 x 2.0
PW306MI0U245*	VPC2864-3851	L21-20	None	5.8	MI	9	0U	IEC320-C13 (36), IEC320-C19 (6)	1.89 x 66 x 2.0
PW309MI0U256*	VPC2864-3852	L21-30	20A (3)	8.6	MI	9	0U	IEC320-C13 (30), IEC320-C19 (6)	1.89 x 66 x 2.0

\*Available July 15, 2010



PW306BA0U246

Catalog Number	Style	Input Plug	Breaker	Max kW	Function	Cord (ft)	Orientation	Receptacles	Dimensions (W x H x D, in)
PW306BA0U246*	VPC2864-3856	L21-20	None	5.8	BA	9	0U	5-20 (18), L6-20 (6)	1.89 x 66 x 2.0
PW306MI0U247*	VPC2864-3857	L21-20	None	5.8	MI	9	0U	5-20 (18), L6-20 (6)	1.89 x 66 x 2.0

\*Available July 15, 2010



PW306SW0U155

Catalog Number	Style	Input Plug	Breaker	Max kW	Function	Cord (ft)	Orientation	Receptacles	Dimensions (W x H x D, in)
PW306SW0U155	IPV70K1-EP1-09L	L21-20	None	5.8	SW	9	0U	5-15 (24)	1.89 x 66 x 2.0





*PW306SW0U156*

Catalog Number	Style	Input Plug	Breaker	Max kW	Function	Cord (ft)	Orientation	Receptacles	Dimensions (W x H x D, in)
PW306SW0U156	IPV70M1-EP1-09L	L21-20	None	5.8	SW	9	0U	IEC320-C13 (24)	1.89 x 66 x 2.0



*PW309MI0U250*

Catalog Number	Style	Input Plug	Breaker	Max kW	Function	Cord (ft)	Orientation	Receptacles	Dimensions (W x H x D, in)
PW309MI0U250	VPC2864-3726	L21-30	20A (3)	8.6	MI	9	0U	IEC320-C13 (36)	1.89 x 66 x 2.0



*PW309SW0U178*

Catalog Number	Style	Input Plug	Breaker	Max kW	Function	Cord (ft)	Orientation	Receptacles	Dimensions (W x H x D, in)
PW309SW0U178	IPV70R1-EP1-09L	L21-30	20A (3)	8.6	SW	9	0U	IEC320-C13 (24)	2.2 x 66 x 2.0

## ePDU Power Tip: Focusing On High Density Power Demands and Trends

Today's ever changing technology has brought the need for high-density IT equipment, bringing forth the demand for more unique power solutions. The majority of data centers are looking to high-density blade servers, which can provide superior levels of performance and reliability. Not only are they more superior they take up a fraction of the space compared to the traditional servers. Blade servers were designed to pack greater processing power into a more compact area, resulting in larger quantities of data storage per square foot. As with every leap in technology usually new problems arise. One very significant problem data centers are facing with the high-density trend, is powering these dense racks of sophisticated IT equipment. Blade servers can have as many as eight power supplies, each with C19 connections.

Focusing on the power needs of these high-density applications comes new strides in power management. Eaton's high-density ePDUs provide a way to distribute power to these mission critical devices. Traditionally a single rack of equipment would have one or two 20-amp power strips mounted in them. In recent years it has gone to one or two 30-amp strips. The newest generations of power distribution solutions is a high-density strip that provides 50-60 amps. This approach allows an entire rack of equipment to be powered from a single power cord input. Thus reducing cabling costs and cable clutter when compared to mounting multiple power strips in an electronic enclosure. Eaton's innovative high-density ePDUs are ideal for the most power intense environments.



## Ultra High Density ePDUs

Intended to power racks with up to four blade server chassis and other power-hungry pieces of IT equipment and virtualized servers. These power distribution units have 50 and 60A inputs, up to 6 distribution breakers, load current monitoring per section and hardwire input options.

**Three Phase**  
208V three phase  
DELTA (CS8365 50A, IEC60309 60A)

### Horizontal Mounts



PW314BA1U193

Catalog Number	Style	Input Plug	Breaker	Max kW	Function	Cord (ft)	Orientation	Receptacles	Dimensions (W x H x D, in)
PW314BA1U193	T17C19250-3-009	CS8365	20A (6)	14.4	BA	9	1U	IEC320-C19 (6)	17 x 1.75 x 7



PW317MI2U141

Catalog Number	Style	Input Plug	Breaker	Max kW	Function	Cord (ft)	Orientation	Receptacles	Dimensions (W x H x D, in)
PW317MI2U141	PC3623	IEC309-60	20A (6)	17.3	MI	10	2U	IEC320-C19 (12)	19 x 3.5 x 17

### Vertical Mounts



PW314BA0U251

Catalog Number	Style	Input Plug	Breaker	Max kW	Function	Cord (ft)	Orientation	Receptacles	Dimensions (W x H x D, in)
PW314BA0U251*	VPC2864-3858	CS8365	20A (2) 30A (1)	14.4	BA	9	0U	IEC320-C13 (24), IEC320-C19 (4), L6-30(2)	1.89 x 66 x 2.0
PW314MI0U252*	VPC2864-3859	CS8365	20A (2) 30A (1)	14.4	MI	9	0U	IEC320-C13 (24), IEC320-C19 (4), L6-30(2)	1.89 x 66 x 2.0

\*Available July 15, 2010



PW314BA0U253

Catalog Number	Style	Input Plug	Breaker	Max kW	Function	Cord (ft)	Orientation	Receptacles	Dimensions (W x H x D, in)
PW314BA0U253*	VPC2864-3853	CS8365	20A (3)	14.4	BA	9	0U	IEC320-C13 (30), IEC320-C19 (6)	1.89 x 66 x 2.0
PW314MI0U254*	VPC2864-3854	CS8365	20A (3)	14.4	MI	9	0U	IEC320-C13 (30), IEC320-C19 (6)	1.89 x 66 x 2.0

\*Available July 15, 2010



PW317MI0U222

Catalog Number	Style	Input Plug	Breaker	Max kW	Function	Cord (ft)	Orientation	Receptacles	Dimensions (W x H x D, in)
PW317MI0U222	VPC3690	IEC309-60	20A (6)	17.3	MI	9	0U	IEC320-C13 (12), IEC320-C19 (12)	1.89 x 66 x 2.0

## ePDU Power Tip: Why Fuse? Circuit Breakers = Reliability

While there is little dispute that fuses can be substituted as over-current protection devices in place of more expensive, and larger circuit breakers, the purchaser of these power controllers must also consider the overall protection reliability of the system design and the total cost of ownership. Both devices react to a current overload condition in approximately the same time (around one-half of a 60 Hz A.C. cycle) and both can be specified with comparable over-current trip limits. Also, if properly designed, both over-current protection devices protect both local and upstream circuits. Power distribution units conforming to UL60950-1 standards must use circuit breakers or fuses rated as 'Branch Circuit Protectors' according to NEC or UL listing. The appropriate circuit breaker type is a UL489 listed unit and the appropriate fuse type is a UL248 listed JDDZ fuse classified for branch circuit protection.

- Circuit breakers, however, provide a wider variety of protection capability and are available in a greater range of trip characteristics. Using the configurability options of the electro-magnetic circuit breaker allows the designer to include additional contacts which may be used to signal the on, or off, state of the breaker, a capability not available with the fuse.
- Circuit breakers are less susceptible to temperature variations and they can also provide manual switching control.
- Unlike fuses there are no replaceable elements in a circuit breaker, so there is no need to keep extras on hand.
- Circuit breakers do not show significant aging effects from repeated near over-current events while a fuse when subjected to the same environment may show a reduction in the fusible current limit.
- Increases in temperatures forming localized hot spots in an equipment rack, or data center, can result in the fuse blowing below its rated value. These hot spots do commonly occur in commercial and industrial settings. In some instances, fuses can explode under extremely high overload and when this happens, the resulting metallic vapor cloud can become a conducting path. This can result in an aberrant circuit path which could result in melted wiring or may spark a fire.
- Another important advantage of the circuit breaker is that it can be tested, and there is no way this can be done with a fuse. While you can test vast quantities of similar fuses, all this will do is provide some assurance of manufacturing quality and repeatability; it is no substitute for a test of the actual protective limiting device in the power controller.

When making the choice between these two protective elements, you must be cognizant of these differences and the resulting total protection reliability and cost of implementation.



## Automatic Transfer Switch ePDU

Designed for switching non-phase synchronized AC power sources, the intelligent circuitry monitors both inputs, providing a fast switch transfer from primary to secondary source to power critical equipment without interruption. Status LEDs indicate power available and output source.

### Features:

- Dual power inputs automatically select a source best suited to power critical equipment
- Relays meet agency spacing requirements for out of phase switching up to 30 amps, while still performing fast enough to minimize transfer time



*PWATSSC20001*

Catalog Number	Style	Input Plug	Breaker	Max kW	Function	Cord (ft)	Orientation	Receptacles	Dimensions (W x H x D, in)
<a href="#">PWATSSC20001</a>	<a href="#">T2235-AB-NNBC20</a>	2 x C20	None	1.9	BA	NA	1U	IEC320-C13 (8), IEC320-C19 (1)	19 x 1.72 x 7
<a href="#">PULSTS1400R-1U</a>	<a href="#">66027</a>	2 x 5-15	None	1.4	MO	6	1U	5-15 (6)	19 x 1.72 x 9.8
<a href="#">PULSTS16AMPR-1U</a>	<a href="#">66028</a>	2 x C20	None	1.9	MO	6	1U	IEC320-C13 (6), IEC320-C19 (1)	19 x 1.72 x 9.8



*PWATSS515002*

Catalog Number	Style	Input Plug	Breaker	Max kW	Function	Cord (ft)	Orientation	Receptacles	Dimensions (W x H x D, in)
<a href="#">PWATSS515002</a>	<a href="#">T2235-A1-NNB09S</a>	2 x 5-15	None	1.4	BA	9	1U	5-15 (8)	19 x 1.72 x 7
<a href="#">PWATSS520003</a>	<a href="#">T2235-A2-NNB09S</a>	2 x 5-20	None	1.9	BA	9	1U	5-20 (8)	19 x 1.72 x 7
<a href="#">PWATSL520004</a>	<a href="#">T2235-A2-NNB09L</a>	2 x L5-20	None	1.9	BA	9	1U	5-20 (8)	19 x 1.72 x 7
<a href="#">PWATSL530005</a>	<a href="#">T2235-C2-CNB09L</a>	2 x L5-30	20A (2)	2.9	BA	9	1U	5-20 (8)	19 x 1.72 x 7



*PWATSL630006*

Catalog Number	Style	Input Plug	Breaker	Max kW	Function	Cord (ft)	Orientation	Receptacles	Dimensions (W x H x D, in)
PWATSL630006	T2235-F3-CNB09L	2 x L6-30	20A (2)	5.0	BA	9	1U	IEC320-C13 (12)	19 x 1.72 x 7



*PWATSL530007*

Catalog Number	Style	Input Plug	Breaker	Max kW	Function	Cord (ft)	Orientation	Receptacles	Dimensions (W x H x D, in)
PWATSL530007	T2235-3369	2 x L5-30	30A (1)	2.9	BA	9	1U	L5-30 (1)	19 x 1.72 x 7
PWATSL630008	T2235-3358	2 x L6-30	None	5.0	BA	9	1U	L6-30 (1)	19 x 1.72 x 7



## ePDU V55 part number guide

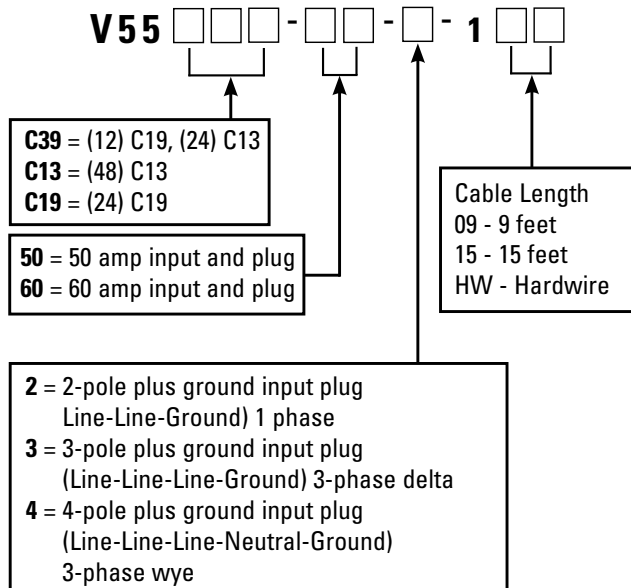

## V55 Ultra High Density ePDU

The ePDU V55 series high-density power distribution units integrate current and temperature monitoring into a 60A vertical strip. This three-phase solution allows for branch circuit monitoring of up to 48 outlets over Ethernet. The configuration options include C13 or C19 outlets, which are connected to six branch circuit breaker sections, with load current monitoring for each section. Output voltage is 208V to provide power supply efficiency and there is a local LED amp display. Additionally, the unit is Ethernet enabled and there is integrated temperature for two locations with optional probes.

### Features:

- Detachable mounting brackets allow for several mounting options. Tool-less mounting hardware included
- Six two-pole 20-amp circuit breakers are located on the front panel
- UL 489 Listed electromagnetic circuit breaker meet branch circuit breaker requirements
- Breaker switch is flush with panel when on to prevent accidental shut off and shows red when in the off or tripped position
- Power input cable length options of nine or 15 feet
- Power input option of terminal block input
- C13 versions have (48) IEC 60320 type C13 receptacle. Each circuit breaker protects eight receptacles
- C19 versions have (24) IEC 60320 type C19 receptacles
- C39 versions have (12) C19 and (24) C13 receptacles. Each circuit breaker protects six receptacles
- Input options of 50 or 60 amps
- Single or three-phase inputs are optional
- Ideal for blade servers or other power demanding applications



Red color indicates when the breaker is off. Circuit breaker switch is flush in the on position to prevent accidental turn off.



Power input option of terminal block input.





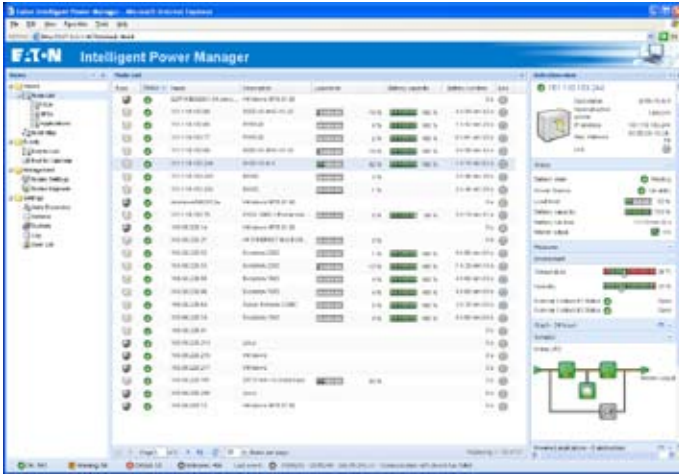

## Intelligent Power Manager

Ideal for monitoring and managing multiple power and environmental devices, Intelligent Power Manager (IPM) software from Eaton delivers a global view across your network from any PC with an Internet browser. Exceptionally versatile, the software is compatible with devices supporting a network interface, including:

- Other manufacturer's UPSs
- Environmental sensors
- ePDUs
- Shutdown applications

IPM is also compatible with VMware's vCenter™ Server so you can monitor your power and network devices from the same dashboard. In the event of a power interruption, the software will alert vMotion to move your virtual machines to an available server for zero downtime. To learn more please visit











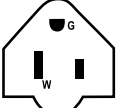
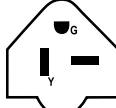

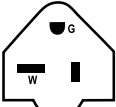
[www.eaton.com/intelligentpower](http://www.eaton.com/intelligentpower).

EASY MANAGEMENT	COST-EFFECTIVE SOLUTION	VERSATILE OPTIONS	SUPPORT FOR IT/NETWORK MANAGERS	EASILY SCALABLE TOOL	TASK AUTOMATION	MASS CONFIGURATION
<ul style="list-style-type: none"> <li>• Provides a global view of all devices from any PC on the network</li> <li>• Enables users to organize a management table by several different criteria (including IP address, application type, owner), centralize alarms and maintain event logs for installed devices</li> </ul>	<ul style="list-style-type: none"> <li>• All the functionality of an enterprise-class monitoring solution at a fraction of the cost-an exceptional alternative for small business needs</li> <li>• Bundled free for up to ten monitored devices; additional nodes can be purchased</li> </ul>	<ul style="list-style-type: none"> <li>• Remotely monitor power or environmental devices, even other manufacturers', that have a simple network interface</li> <li>• Monitor environmental sensors, ePDUs and other devices</li> </ul>	<ul style="list-style-type: none"> <li>• Places vital information directly into the hands of IT and network managers, helping them to better manage their data center environments</li> <li>• Shows dependencies between protected equipment and UPSs</li> </ul>	<ul style="list-style-type: none"> <li>• Upload custom floor plans or maps directly into the system</li> </ul>	<ul style="list-style-type: none"> <li>• Assign automatic actions to power or environmental events, including e-mail notification and running scripts</li> </ul>	<ul style="list-style-type: none"> <li>• Save time and money during large roll-outs by mass configuring all Network Management Cards and Network Shutdown Modules</li> </ul>







## ePDU plugs and receptacles



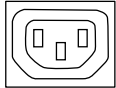

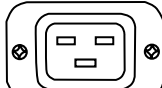

### Standard NEMA Plugs



 <p>5-15 120V 15A 1 phase straight blade</p>	 <p>6-20 208V 20A 1 phase straight blade</p>	 <p>L21-20 120/208V 20A, 3 phase wye</p>	 <p>L22-20 277/480V 20A 3 phase wye</p>
 <p>5-20 120V 20A 1 phase straight blade</p>	 <p>L6-20 208V 20A 1 phase twist lock</p>	 <p>L21-30 120/208V 30A 3 phase wye</p>	 <p>L22-30 277/480V 30A 3 phase wye</p>
 <p>L5-20 120V 20A 1 phase twist lock</p>	 <p>L6-30 208V 30A, 1 phase</p>	 <p>L15-20 208V 20A 3 phase delta</p>	
 <p>L5-30 120V 30A 1 phase twist lock</p>	 <p>L14-30 120/240V 30A 2 phase (split phase)</p>	 <p>L15-30 208V 30A 3 phase delta</p>	

### IEC 60320

 <p>C13</p>	 <p>C14</p>	 <p>C19</p>	 <p>C20</p>
North American	15A	250 volts	20A
Europe	10A	250 volts	16A
			250 volts

### IEC 60309

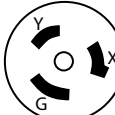
 <p>30A</p>	 <p>60A</p>	 <p>30A</p>	 <p>60A</p>	 <p>60A</p>	 <p>60A</p>
2P3W	2P3W	4P5W	3P4W	4P5W	4P5W
250V	250V	3ØY230/400V	3Ø250V	3ØY120/208V	3ØY230/400V

 <p>HBLCS8265C</p>
50A, 2P3W 250V
 <p>HBLCS8365C</p>
50A, 3P4W 3Ø250V

### The IEC Advantage:

The IEC 60320 and IEC 60309 connectors described below are the most commonly specified. The IEC connector system is used throughout the world. By utilizing an Eaton ePDU with the IEC connectors, you can attach the correct cable assembly for British, Australian, Continental European, North American and many other cable/connector configurations. This allows you to purchase and inventory one ePDU for shipment anywhere in the world.

## Splitter Cables



**CBL139 Splitter Cable**  
L14-30R to (2) L6-30R (4 ft/2 ft)



**CBL143 Splitter Cable**  
L14-30R to (2) L5-30R (4 ft/2 ft)



**CBL148 Splitter Cable**  
L14-20R to (2) L5-20R (4 ft/2 ft)



**CBL149 Splitter Cable**  
L21-30R to (3) L5-30R (4 ft/2 ft/1 ft)



**CBL150 Splitter Cable**  
L21-20R to (3) L5-20R (4 ft/2 ft/1 ft)

## Power cables and accessories

By turning to Eaton, you and your customers can enjoy one-stop shopping for a full range of power quality and power distribution needs, including power cables. The Eaton cable portfolio includes nearly two dozen choices in three product categories including adapters, jumpers and splitters

All Eaton power cables are tested and certified for use with Eaton products, such as ePDUs, rack power modules (RPMs) and UPSs—proven to deliver the reliability and service life needed for the most rigorous data center applications.

## Adapter cables



**010-0032:**  
C14 to NEMA 5-15R  
125V, 15A  
1 foot, 16 AWG/3-wire



**010-9335:**  
NEMA 5-20P to C19  
125V, 20A straight blade  
8-foot, 12 AWG/3-wire



**010-9337:**  
NEMA 6-20P to C19  
250V, 20A straight blade  
8-foot, 12 AWG/3-wire



**010-9339:**  
NEMA L5-20P to C19  
125V, 20A twist-lock  
8-foot, 12 AWG/3-wire



**010-9341:**  
NEMA L6-20P to C19  
250V, 20A twist-lock  
8-foot, 12 AWG/3-wire



**010-9342:**  
C20 Male to C19  
20A  
8-foot, 12 AWG/3-wire



**010-9334:**  
NEMA 5-15P to C19  
125V, 15A straight blade  
8-foot, 14 AWG/3-wire



**010-9336:**  
NEMA 6-15P to C19  
250V, 15A straight blade  
8-foot, 14 AWG/3-wire



**010-9338:**  
NEMA L5-15P to C19  
125V, 15A twist-lock  
8-foot, 14 AWG/3-wire



**010-9340:**  
NEMA L6-15P C19 to  
250V, 15A twist-lock  
8-foot, 14 AWG/3-wire

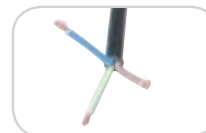

**010-0034:**  
8-foot, 12 AWG/3-wire  
C19 to bare wire  
(Pig Tail)

## Jumper Cables



**010-0025:** 8-foot  
**010-0027:** 6-foot  
**010-0028:** 4-foot  
**010-0029:** 2-foot  
C14 to C13

## Outlet Caps



**035-0113:**  
C13 outlet cap



**035-0119:**  
C19 outlet cap

## Space-saving mounting options

Installing your new ePDU is quick and easy. There are models that mount horizontally in minimal rack space (1U or 2U), or vertically in rack side pockets or rear channels—or on a wall or floor, saving traditional U space for IT equipment.

The units come with all mounting hardware included, ready to install. There's no need to purchase additional mounting hardware or accessories. Some units use a button-mount system and can be mounted in keyhole-type openings in popular racks, with no tools required.

### Horizontal mounting

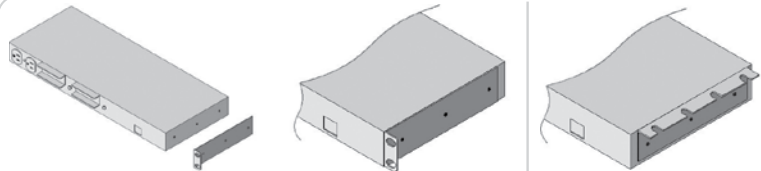

Mounting Brackets Are Detachable With Several Mounting Options Shown

Front Flush

Optional Zero-U Bracket  
Part Number - 001-1928-1

**Rack Mounting Hole Specification Table**

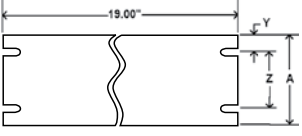

HOLE SPECIFICATION TABLE

A	Y	Z
1.75	.25	1.25
3.5	.875	1.75
5.25	.875	3.5

### Vertical mounting



SUB-HRDWARE-017 - Standard mounting included, brackets come attached to units.

Tool-less Mounting

### Benefits of vertical mounts

Eaton ePDUs can be mounted vertically, allowing you to save valuable space. You can mount the racks vertically in rack side pockets, rear channels – or on a wall, which allows you to save traditional U space for IT equipment.

UNITED STATES  
8609 Six Forks Road  
Raleigh, NC 27615 U.S.A.  
Toll Free: 1.800.356.5794

[www.epdu.com](http://www.epdu.com)



*Powering Business Worldwide*

CANADA  
Ontario: 416.798.0112  
Toll Free: 1.800.461.9166

LATIN AMERICA  
South Cone: 54.11.4124.4000  
Brazil: 55.11.3616.8500  
Andean & Caribbean:  
1.949.452.9610  
Mexico & Central America:  
52.55.9000.5252

EUROPE/MIDDLE EAST/AFRICA  
Denmark: 45.3686.7910  
Finland: 358.94.52.661  
France: 33.1.6012.7400  
Germany: 49.0.7841.604.0  
Italy: 39.02.66.04.05.40  
Norway: 47.23.03.65.50  
Portugal: 55.11.3616.8500  
Sweden: 46.8.598.940.00  
United Kingdom: 44.1753.608.700



PowerChain  
Management®

ASIA PACIFIC  
Australia: 61.2.9693.9366  
New Zealand: 64.0.3.343.3314  
China: 86.21.6361.5599  
HK/Korea/Taiwan: 852.2745.6682  
India: 91.11.4223.2300  
Singapore/SEA: 65.6825.1668

Eaton, Powerware, PowerChain Management  
and ePDU are trade names, trademarks, and/  
or service marks of Eaton Corporation or its  
subsidiaries and affiliates.

©2010 Eaton Corporation  
All Rights Reserved  
Printed in USA  
EPDUCAT  
April 2010